

**TARGET SHOOTING
NEW ZEALAND
INCORPORATED**



**DESIGNATED MATCHES
MANUAL**

(1 January 2018)

Target Shooting New Zealand Inc
P.O Box 1347, Palmerston North 4440, New Zealand
Ph: 00 64 6 353 0609, Mob: 00 64 22 313 0609
Email: targetshootingnz@xtra.co.nz
Website: www.tsnz.nz

Target Shooting NZ Inc - Constitution and Outdoor Rules:

3.10 DESIGNATED MATCHES

- 3.10.1 Designated Matches are those matches used by TSNZ as selection matches for various international events. TSNZ in conjunction with NZSF will determine which matches will be Designated Matches. These will be listed on the TSNZ website. There are a limited number of matches which may be held annually.
- 3.10.2 Any shooter wanting to attend international competitions such as World Cups, World Championships, Oceania Championships, Commonwealth Shooting Championships, Commonwealth Games or Olympic Games will need to attend some, or all, of these Designated Matches.
- 3.10.3 Range Standards and Competition Conditions for Designated Matches and other matches which are used for International selection shall be as close as practicable to ISSF Rules.
- 3.10.4 Any Club or Association wanting to hold a Designated Match may apply to TSNZ and will need to demonstrate their ability to hold a championship to ISSF Rules. Allocation of the limited number of Designated Matches will be decided on merit.

There are seven (7) Designated Matches held each season for each of the 50m Prone, 3P and Air disciplines.

Designated Matches are confirmed by NZSF and TSNZ and are placed on the TSNZ Calendar in advance of each shooting season, and in advance of the setting of any selection criteria that NZSF (New Zealand Shooting Federation) will require them for (eg Oceania, Commonwealth Games etc). No changes to Designated Matches can be made once those selection criteria are made public.

Designated Matches are also included in the TSNZ 10-Year Plan. However, as the dates and or locations may change in any specific year, the most recent 10-Year Plan must be used, and even this plan should not be used for committing to any plans or bookings without first checking the most recent Outdoor/Air Calendar.

Associations that host and run Designated Matches must be able to provide a fair and even playing field for all shooters, and all conditions that are under their control must be managed to allow the best possible scores for those shooters.

For this reason, this Manual outlines the NZ conditions that are required for running TSNZ Designated Matches, along with additional conditions that are recommended.

Conditions for TSNZ Designated Matches – 50m Prone & 3P

These conditions should be read in conjunction with
TSNZ Outdoor Rules & ISSF Rules.

PART ONE – REQUIRED conditions:

- Names of Chief Range Officer and Range Committee (3 members) must be advised to TSNZ at least a week in advance of the event
- Target changers must be used (unless Electronic Targets are available).
- The target changers must be adequately secured to the ground so that they will not move or blow over.
- Lids of the target changers must be adequately secured so that they will not blow off.
- Target changers must have backs inserted to enclose shot targets and prevent them becoming damp or blowing away.
- An adequate battery/power supply must be provided to allow all targets to move forward at the same time without significant slowing.
- There must be an adequate system of gathering shot targets and getting them quickly to the marking room without them becoming wet or damaged in any way.
- Mound/Firing Point numbers must be added to the target underneath the diagram, not out to the side. This is so the number is not cut off when the target is run through the cutter prior to marking.
- The number of the first lead-in target must be entered in a record sheet against each mound number before each match.
- All targets in one shooter's set must be kept together in numerical order according to the numbering pre-printed at the top of the diagram (eg 440993, 440994, 440995 etc)
- Flags must be provided in a fair manner for ALL shooters. This includes providing flags preferably between each mound but at a minimum of every 2 mounds, and **at least 2 flags**, but more if possible, to the left of the left-most shooter, and the same to the right of the right-most shooter. If 2 flags outside the left- and right-most shooters are not possible due to range shape or surrounding contours, the outmost mounds should not be used.
- All range calls and instructions must be made in accordance with the TSNZ range manuals.

- Copies of the current TSNZ Outdoor Rules and ISSF Rules must be available on the range and in the marking room.
- Marking must be done using Disag marking machines and the Match Manager programme (provided by TSNZ).
- Adequate marking room space must be available for setting up of marking equipment, including cutter, Disag, laptops etc. This equipment will be provided by TSNZ.
- Adequate numbers of helpers must be available for marking – a minimum of 4 people. These people must be available to work immediately following the end of the match.
- Official scores must be produced and provided to TSNZ using information directly from Match Manager output, and not be entered into any other spreadsheets manually first.

PART TWO – RECOMMENDED conditions, only where practicable:

- Targets should be taped (using masking tape) at the sides on their joins where they are most at risk of splitting, eg between the last sighter and the first match diagrams.
- Target changers should have a system of keeping the target faces dry when loaded in the changers to protect them in the event of rain, eg rain shades.
- On ranges where it is difficult to see shot holes, a white or light coloured board should be placed several metres behind the target changer to provide the best possible view of shot holes through shooters' scopes.
- Targets should not be left loaded into the target changers overnight without adequate protection to prevent damp.
- Flags should not be left out overnight to become damp.
- At least 1 spare mound but more if possible should be kept available for shooters to be moved to in the event of changer breakdown.
- If pre-entries are taken, the pre-entry time should close one week before the match and the entries sent to TSNZ so that Match Manager can then be pre-loaded.
- Ideally marking helpers should not also be shooters in the matches being marked.

PART THREE - TARGET PREPARATION:

a) 50M PRONE MATCH:

- Single diagram fanfold paper targets as supplied by TSNZ must be prepared in the following layout – 36 targets for each shooter:
 - 1 lead-in diagram
 - 4 sighting diagrams
 - 30 counting diagrams (for 2 shots per diagram)
 - 1 tail-out diagram
- Marking of target diagrams must be done using the TSNZ standard format:

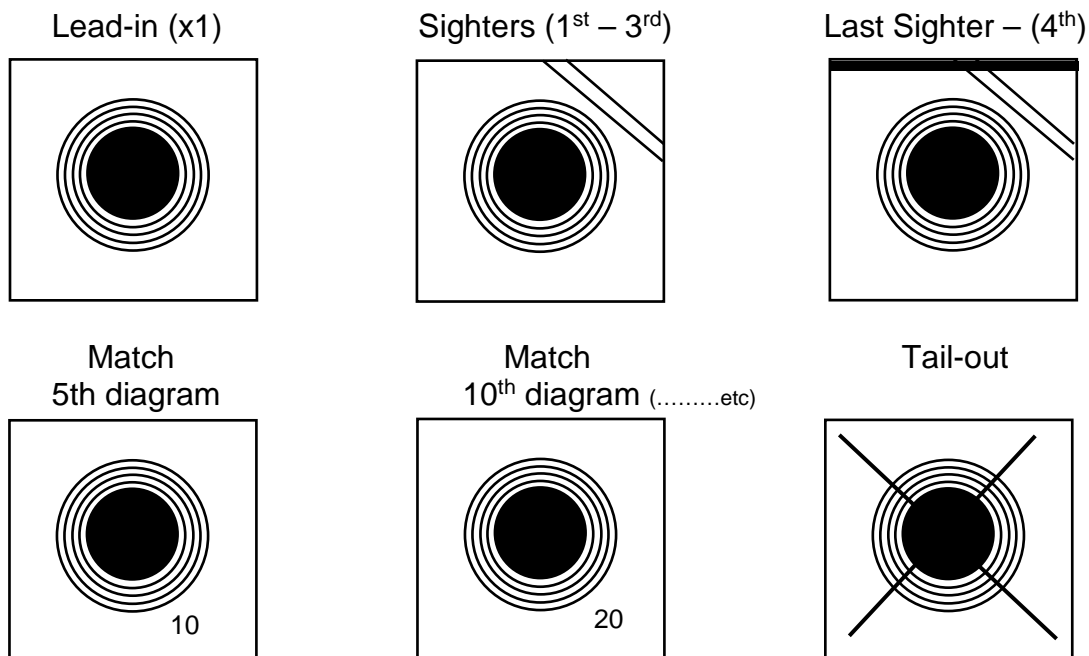

b) 50M PRONE FINAL:

- Single diagram fanfold paper targets as supplied by TSNZ must be prepared in the following layout – 30 targets for each shooter:
 - 1 lead-in diagram
 - 4 sighting diagrams
 - 24 counting diagrams (for 1 shot per diagram)
 - 1 tail-out diagram
- Target markings for lead-in, sighters and tail-out are the same as for the match.
- Every counting diagram is marked in the same location as the 10, 20 etc are marked on the match targets with Firing Point letters A-H plus targets 1 – 24.(eg A1 A2 A3.... – H1 H2 H3.....)

c) 3P MATCH:

- Single diagram fanfold paper targets as supplied by TSNZ must be prepared in the following layout – 76 targets for each shooter:
 - 1 lead-in diagram
 - 4 sighting diagrams per position = 12
 - 20 counting diagrams (for 2 shots per diagram) per position = 60
 - 1 tail-out diagram for each position = 3
- Marking of target diagrams must be done using the TSNZ standard format, with the sighting/counting/tail diagrams being repeated after each 20 counting diagrams for each change of position (giving a total of 3 sets):

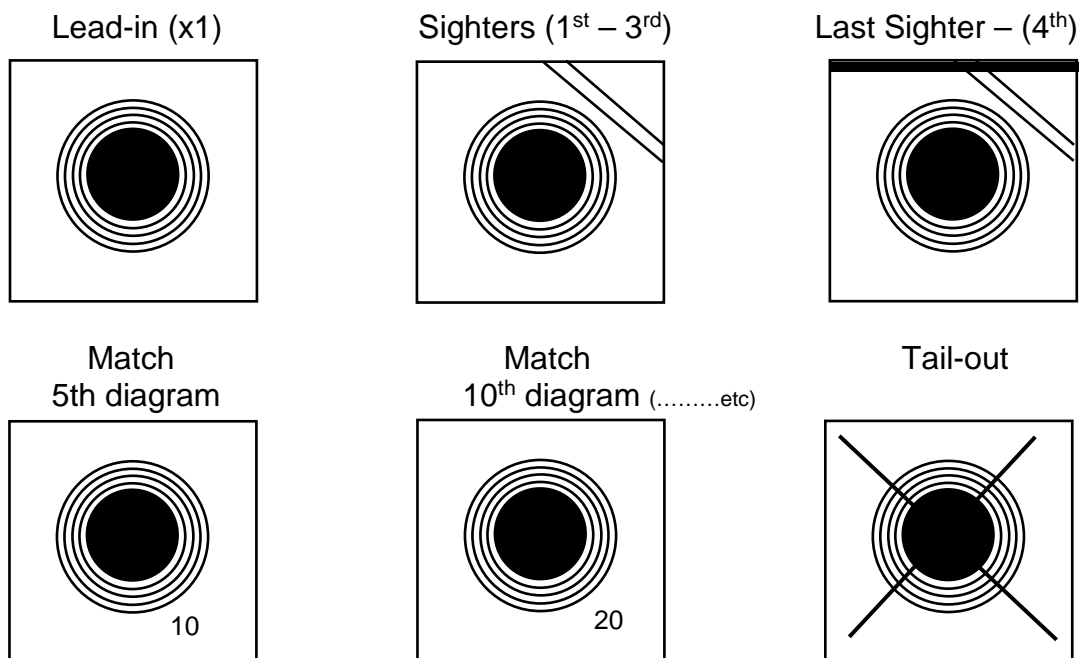

(NOTE – as from 1 January 2018 **both** Men's and Women's matches are 120 shots - 40 shots per position - with both Finals being 15 shots per position)

d) 3P FINAL:

- Single diagram fanfold paper targets as supplied by TSNZ must be prepared in the following layout – 57 targets for each shooter:
 - 1 lead-in diagram
 - 4 sighting diagrams for the first position then 2 sighting diagrams for the next 2 positions = 8
 - 15 counting diagrams (for 1 shot per diagram) per position = 45
 - 1 tail-out diagram for each position = 3
- Target markings for lead-in, sighters and tail-out are the same as for the match.
- Every counting diagram for each position is marked in the same location as the 10, 20 etc are marked on the match targets with Firing Point letters A-H plus targets 1 – 15.(eg A1 A2 A3.... – H1 H2 H3.....)

PART FOUR - MARKING ROOM SETUP

Marking room setup is largely dependent on the size/shape/layout of the space available, and many variations are possible. The diagrams below are recommendations only, intended to show how the FLOW of the targets is best handled for best efficiency.

a) **RECOMMENDED MARKING ROOM SETUP & FLOW for using 1 Disag:**

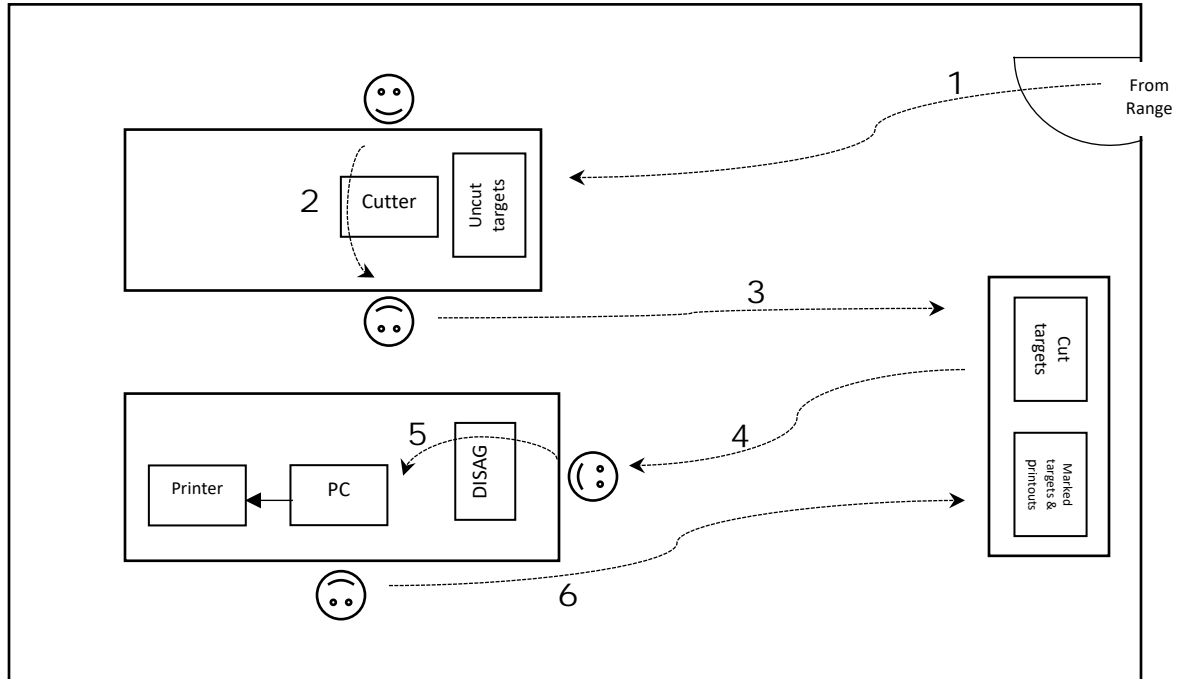

b) **RECOMMENDED MARKING ROOM SETUP & FLOW for using 2 Disags:**

